

MHL™ Technology Brief

Document # Sil-TB-1001

Copyright and Trademark Notice

Copyright © 2008 Silicon Image, Inc. All rights reserved. Silicon Image, the Silicon Image logo, MHL, Mobile High-Definition Link, VastLane, Simplay HD, SiI9220, SiI9222, SiI9224, SiI9290 are trademarks or, registered trademarks of Silicon Image, Inc. in the United States and/or other countries. HDMI, and High-Definition Multimedia Interface are trademarks or registered trademarks of HDMI Licensing, LLC. in the United States and/or other countries. All other trademarks and registered trademarks are the property of their respective owners in the United States and/or other countries.

Table of Contents

Introduction – What is MHL technology?	2
How will consumers benefit from MHL technology?	2
How is MHL technology implemented in mobile CE devices?	3
Why not just equip the mobile device with HDMI output?	3
Why not just use an analog connection between the dongle and the HDTV?	4
In Summary, what are the key features of MHL technology?	4
What Silicon Image products are available that support MHL Technology?	4
About Silicon Image, Inc.	6

Introduction – What is MHL technology?

Mobile HD Link (MHL) technology is a low pin count HD audio and video interface that connects portable electronics devices such as mobile phones, digital cameras, camcorders and portable media players, to HDTVs. The technology allows mobile devices to output digital 1080 Full HD resolution via the existing mobile connector without the real estate and cost of another dedicated video connector. Together with an MHL-to-HDMI bridge, the MHL-enabled mobile device becomes a fully compliant HDMI source and can connect to the television’s standard HDMI input port.

How will consumers benefit from MHL technology?

Mobile devices are now a source of a tremendous amount of multimedia content, including captured high-resolution still images and HD videos, and downloaded feature-length Hollywood films. Unfortunately, when consumers connect these portable devices to an HDTV with an analog composite connection, the native high-definition picture is reduced to below standard definition with poor image quality. MHL technology-enabled devices, however, can connect to HDTVs allowing users to watch and listen to multimedia content on a large screen in its original pristine high-definition digital format.

How is MHL technology implemented in mobile CE devices?

To equip a mobile device with MHL technology, the manufacturer would add an MHL technology transmitter IC to the mobile device. Two pins on the device's connector need to be reserved for a single Transition Minimized Differential Signaling (TMDS) lane carrying audio/video packets and a single pin is reserved for a bi-directional control bus, which supports authentication, A/V format discovery, and various control functions.

MHL technology-enabled mobile devices will connect to the DTV via a docking station or dongle, which includes an MHL-to-HDMI bridge IC that performs the conversion from the uncompressed MHL video signals into standard HDMI compatible signals. The docking station is equipped with a standard HDMI output connector, allowing the docking station to be plugged directly into HDTVs. The docking station can also pass DC power to the mobile device to charge the battery when the device is in the dock.

FIGURE 1: MHL Transmitter, Bridge and HDMI Receiver Implementation



Why not just equip the mobile device with HDMI output?

Physical space for connectors on portable mobile devices such as digital cameras, portable media players and mobile phones is often extremely limited due to the small form factors of these devices. Mobile device manufacturers generally prefer to have a single connector that accommodates power charging, USB and audio/video transfer. The standard HDMI interface would require a dedicated 19-pin HDMI connector, which makes the standard HDMI interface difficult to implement on small devices. MHL technology reduces this pin count requirement for HD audio and video so the technology can be implemented on an existing mobile device connector. This removes the mechanical barrier in designing, qualifying, and paying for another dedicated video connector in mobile form factor applications

Why not just use an analog connection between the dongle and the HDTV?

Analog composite or component video requires up to three video connectors and two to eight audio connectors for multi-channel audio support, for a total of three to 11 connectors while providing only low quality analog 480i picture. This puts a burden on the manufacturer to integrate larger docking stations to accommodate the connectors. In some cases, manufacturers have implemented an interface to transmit compressed media between the mobile device and dock. The dock implements full digital signal processor and supporting circuits to decode compressed media, before outputting uncompressed video to the television. This is an expensive solution duplicating the functions that already exist in the mobile device. MHL technology solves this problem with a low-cost, low pin count interface.

In Summary, what are the key features of MHL technology?

- MHL technology provides HD audio/video with only three pins, enabling high definition audio and video using the mobile device's existing multipurpose connector
- MHL technology conserves battery life with ultra-low active and standby power draw
- MHL technology supports high-quality digital HD video up to 1080p
- MHL technology is compatible with the HDMI input ports found on most DTVs today with an MHL-to-HDMI bridge

What Silicon Image products are available that support MHL Technology?

MHL Transmitters

MHL Transmitters are low pin-count digital media transmitters featuring a single data lane Transition Minimized Differential Signaling (TMDS) solution, which reduces pin count for small devices. These transmitters can deliver full high-definition (HD) video and digital audio through 3 pins on any multipurpose mobile connector. When combined with an MHL-to-HDMI bridge, MHL transmitters form an HDMI-enabled source device fully compliant to HDMI

specifications. MHL Transmitters are available with parallel RGB digital video input. The low active and standby power consumption of MHL transmitters extend battery life in mobile devices.

FIGURE 2: Silicon Image MHL Transmitter Design

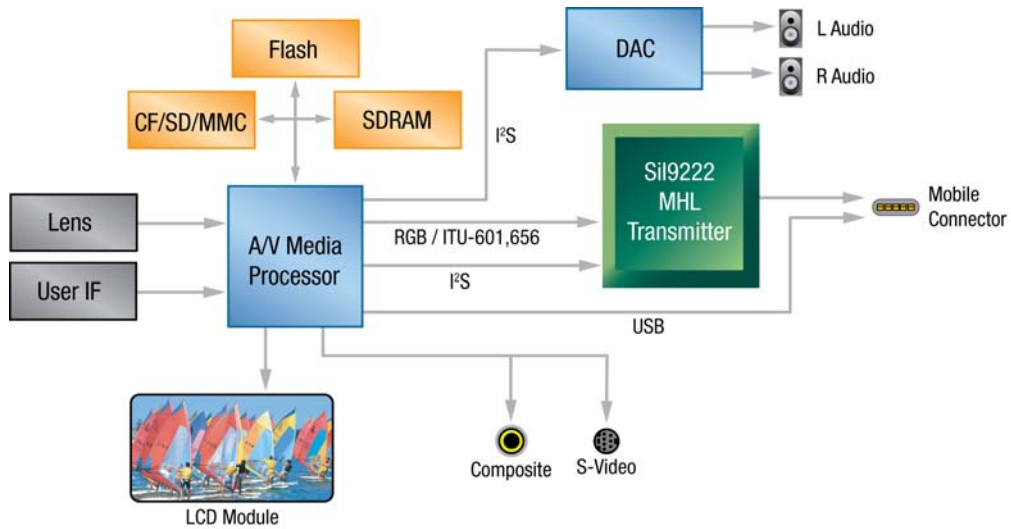

MHL Bridges

MHL-to-HDMI bridges convert an MHL equipped device's audio and video signals into a standard HDMI signal. The MHL bridge provides a cost-effective solution for a docking station or dongle that is fully HDMI compatible.

FIGURE 3: Silicon Image Typical MHL Bridge Implementation

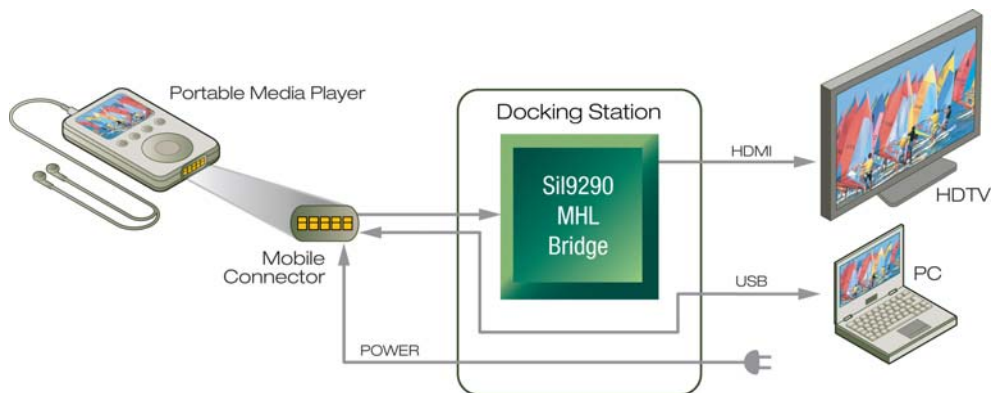

About Silicon Image, Inc.

Silicon Image, Inc. is a global leader in driving the architecture and semiconductor implementation for the secure storage, distribution and presentation of high-definition content in the consumer electronics, personal computing, and mobile device markets. With a rich history of technology innovation that includes creating industry standards such as SATA, DVI and HDMI, Silicon Image partners with the world's leading entertainment creators and electronics manufacturers to deliver digital HD content to consumers anytime, anywhere, on any device. Silicon Image is also a leading provider of semiconductor intellectual property solutions for high-definition multimedia and data storage applications. Additionally, Simplay Labs, LLC, a wholly-owned subsidiary of Silicon Image, offers robust testing tools, technologies, support services, consulting and product certification to electronics manufacturers to maximize performance, interoperability and ensure the highest-quality HD experience to consumers. With engineering, sales and customer support facilities located throughout North America, Asia and Europe, Silicon Image (NASDAQ: SIMG) is globally headquartered in Sunnyvale, California. For more information, please visit www.SiliconImage.com.



60 E. Arques Avenue

Sunnyvale, CA 94085

T 408.616.4000 F 408.830.9530

www.siliconimage.com